

Dock leveller

Crawford DL6020STA

ASSA ABLOY

ASSA ABLOY Entrance Systems

The global leader in
door opening solutions



The efficient and safe docking process

The Crawford DL6020STA Stepdock Autodock is a dock leveller that provides increased efficiency and safety for the docking process. It has a telescopic lip and self supporting frame for easy integration with a building. It is the base of a complete Load house outside the building. The operation is based on the proven telescopic lip technology which is the universal and most flexible docking system. The Crawford DL6020STA Stepdock Autodock provides other advantages than a standard telescopic lip leveller.

The design was specifically developed to let a truck dock to the loading bay with closed rear doors. First the truck is put in the right position and then preferably an inflatable dock shelter seals off the loading bay before the sectional door is opened. The last step of the complete dock-in procedure is that the rear doors of the truck are opened. This sequence "dock first – open the rear doors later" provides a number of benefits: saving of energy, improving working conditions in particular for the truck driver, increasing safety of people / goods, and improving the efficiency of the docking process.

Ideal solution for various applications

- Hygienic transport with high focus on safety.
- Food logistic demanding the unbroken cold chain.
- Container transport with customs purposes.
- High attention on theft prevention.

Crawford 950 series - the intelligent, all in one, docking control system

The innovative and unique 950 series docking control system gives you direct control of the dock leveller, dock shelter and door all in one control unit. With only a few self explaining buttons it is easy to operate, to meet the demands of modern logistics. Separate steering units or complex wiring are no longer needed.

Technical Data

Nominal length ¹	2450 mm
Nominal width	3300, 3500, 3600, 3750 mm
Load capacity	60 kN (6 tonnes)
Vertical working range	
Rise above dock	up to 220 mm
Fall below dock	down to 620 mm
Platform tear-plate thickness	8/10 mm
Max. point load leveller platform	6,5 N / mm ² (8 mm tear plate)
Lip Type and Length	telescopic, 500 mm ergonomic lip, 345 mm
Lip Material	steel or aluminium
Control unit protection class	IP 54
Temperature range hydraulic oil	-20°C - +60°C
European standard	EN 1398 Dock levellers

1) Other sizes on request

Dimensions

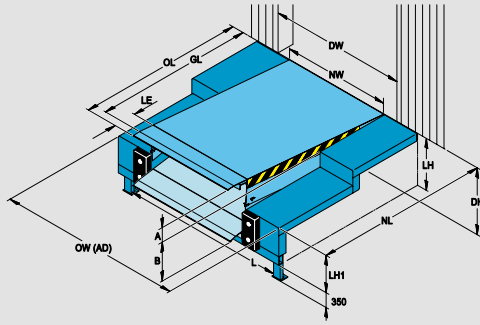

SH	Step height (250 mm)
SL	Step length (1300 mm)
FSH	Free Step height
FSL	Free Step length

Dimensions	Vertical working range				Step		
	LE 500		LE 345		FSL	FSH	
NL	LH / LH1	A	B	A	B	FSL	FSH
2000	850 / 600	220	620	210	600	1140	225

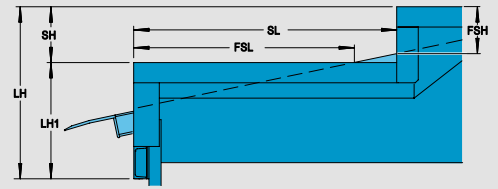

NL	Nominal length
OL	Overall length
GL	Gradient length
NW	Nominal width (2000 mm)
LE	Lip extension
LH / LH1	Leveller heightback / front
A	Working range above dock level
B	Working range below dock level
DH	Dock height
DW	Door width
NW (AD)	Nominal width Autodock (incl. side tread panels)
L	Distance between plinths
OW (AD)	Overall width Autodock = NW (AD) -20

Electrical preparations

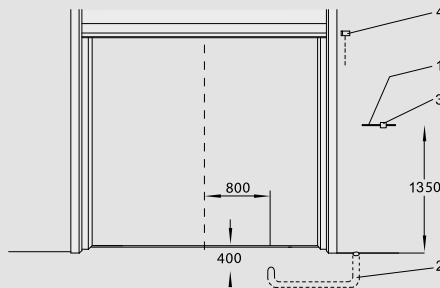

1	Control unit (included in the delivery)
2	Conduit for wiring internal diameter 70, angles <45° (by others)
3	Mains supply: 3 / N / PE AC 50 Hz 230 / 400V Mains fuse: D0 10 A gL Motor power: 1,5 kW
4	Cable: 7 x 0,75 mm ²
5	Motor cable: 4 x 1,5 mm ²
6	Optional safety switch on sectional door to disable leveller when door is closed*

*Non standard

Operating functions for Tele lip levellers

950 LA TD	950 DLA TD	950 LSA TD	950 DLSA TD	
				<p>TD = Teledock L = Leveller A = Auto Button D = Door S = Shelter</p>

Standard available colours

	Red RAL 3002		Green RAL 6005		Hot dip galvanised
	Blue RAL 5010		Jet Black RAL 9005		